

SCC Series – Part Numbering



Features

- Rugged
- Light weight
- Low cost
- General purpose

Applications

- Industrial

Part Numbering

Part Number		Size	Number of Contact	Suffix (Contact Type)	Notes	Page
Series	Prefix (Body)					
SCC	6A	13,16,21,25	13 size : 3 or 5	P	Plug(Pin)	12
				S	Plug(Socket)	13
	2A		16 size : 7 or 10	P	Receptacle(Pin)	13
				S	Receptacle(Socket)	12
	1A		25 size : 16 or 24	P	Adapter(Pin)	13
				S	Adapter(Socket)	12

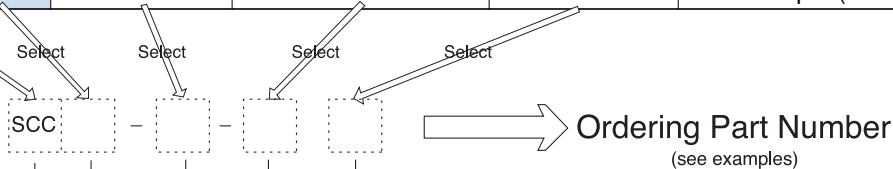

Connector Series (Body Type)

- SCC6A - Plug
- SCC2A - Receptacle
- SCC1A - Adapter

Size

13,16,21,25

No. of Contact

- 13 Size : 3 or 5
- 16 Size : 7 or 10
- 21 Size : 10 or 16
- 25 Size : 16 or 24

Contact Type

- P : Pin
- S : Socket

Examples

SCC6A - 13 - 3P

SCC series Plug - Size 13 - 3 pin

SCC2A - 16 - 10S

SCC series Receptacle - Size 16 - 10 socket

SCC1A - 25 - 24P

SCC series Adapter - Size 25 - 24 pin

Specifications subject to change without notice. Consult Sam Woo Electronics for the latest specifications.

Major Performances / Contact Arrangements

Performance	Size/No of Contacts	Size 13		Size 16	
		3	5	7	10
Withstanding Voltage (per min) ¹		AC 250V	AC 250V	AC 250V	AC 250V
Current		10A	5A	10A	5A
Insulation Resistance (Minimum) ²		1,000MΩ	1,000MΩ	1,000MΩ	1,000MΩ
Contact Resistance (Maximum) ³		5mΩ	5mΩ	5mΩ	5mΩ
Solder Pot Inside Diameter (∅)		1.5	1.0	1.5	1.0
Contact Arrangement					
Performance	Size/No of Contacts	Size 21		Size 25	
		10	16	16	24
Withstanding Voltage (per min) ¹		AC 250V	AC 250V	AC 250V	AC 250V
Current		10A	5A	10A	5A
Insulation Resistance (Minimum) ²		1,000MΩ	1,000MΩ	1,000MΩ	1,000MΩ
Contact Resistance (Maximum) ³		5mΩ	5mΩ	5mΩ	5mΩ
Solder Pot Inside Diameter (∅)		1.5	1.0	1.5	1.0
Contact Arrangement					

- ¹ Withstanding voltage is the tested voltage value in this table.
- ² Insulation resistance is measured at DC 100V.
- ³ Contact resistance is measured at DC 1A.
- Values are from tested items and may not apply to all connectors.
- Specifications subject to change without notice.
- Consult Sam Woo Electronics for the latest specifications.

Material Used / Finishing Material

		Material	Finish
Body		Aluminum alloy	Ni plate
Insulator		Thermosetting resin	UL94V-0 ; Blue
Contacts	Pin	Copper alloy	Silver plate
	Socket	Copper alloy	Silver plate

Mating & Unmating Force

Shell Size	Contacts	Force	Shell Size	Contacts	Force
13	3	< 1.4Kg	13	5	<1.5Kg
16	7	< 3.2Kg	16	10	< 3.4Kg
21	10	< 4.5Kg	21	16	< 5.5Kg
25	16	< 7.2Kg	25	24	< 8.2Kg

SCC Series Mini-map



Specifications subject to change without notice. Consult Sam Woo Electronics for the latest specifications.

SCC Series – Male Plug, Female Receptacle / Adapter

SCC6A Plug



SCC6A-25-24P

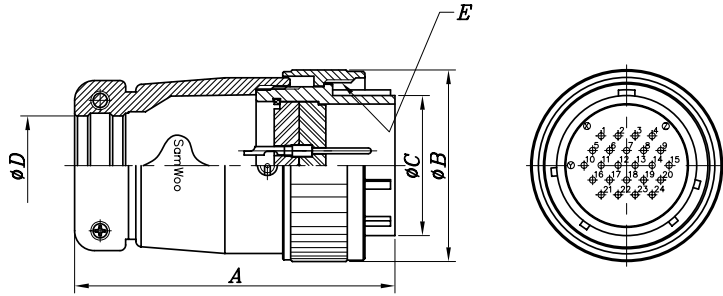

Part Number	A	ØB	ØC	ØD	E
SCC6A-13-3P	45.7	21.5	12.7	8.0	M18×1.0P
SCC6A-13-5P					
SCC6A-16-7P	48.0	25.5	16.3	11.5	M22×1.0P
SCC6A-16-10P					

Part Number	A	ØB	ØC	ØD	E
SCC6A-21-10P	53.5	29.7	20.5	14.0	M26×1.0P
SCC6A-21-16P					
SCC6A-25-16P	56.5	33.8	24.7	17.5	M30×1.0P
SCC6A-25-24P					

SCC2A Receptacle



SCC2A-25-24S

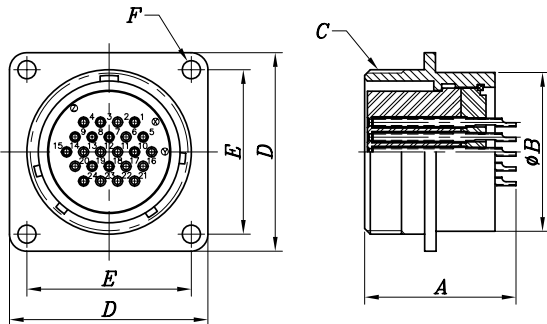

Part Number	A	ØB	C	D	E	F
SCC2A-13-3S	27.8	16.0	M18×1.0P	26.0	20.0	4-Ø3.3
SCC2A-13-5S	26.5					
SCC2A-16-7S	27.6	19.8	M22×1.0P	29.0	23.0	4-Ø3.3
SCC2A-16-10S	27.0					

Part Number	A	ØB	C	D	E	F
SCC2A-21-10S	27.1	24.0	M26×1.0P	32.0	26.0	4-Ø3.3
SCC2A-21-16S	26.6					
SCC2A-25-16S	27.3	27.9	M30×1.0P	35.0	29.5	4-Ø3.3
SCC2A-25-24S	26.7					

SCC1A Adapter



SCC1A-25-24S

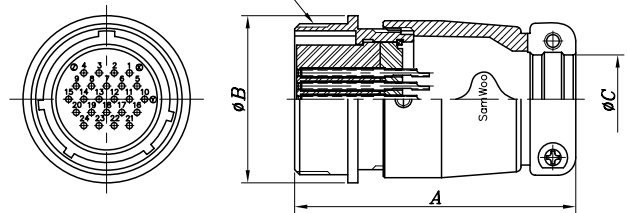

Part Number	A	ØB	ØC	ØD
SCC1A-13-3S	45.0	21.0	8.0	M18×1.0P
SCC1A-13-5S				
SCC1A-16-7S	47.8	25.0	11.5	M22×1.0P
SCC1A-16-10S				

Part Number	A	ØB	ØC	ØD
SCC1A-21-10S	51.5	29.0	14.0	M26×1.0P
SCC1A-21-16S				
SCC1A-25-16S	55.5	33.0	17.5	M30×1.0P
SCC1A-25-24S				

Specifications subject to change without notice. Consult Sam Woo Electronics for the latest specifications.

Female Plug, Male Receptacle / Adapter – SCC Series

SCC6A Plug

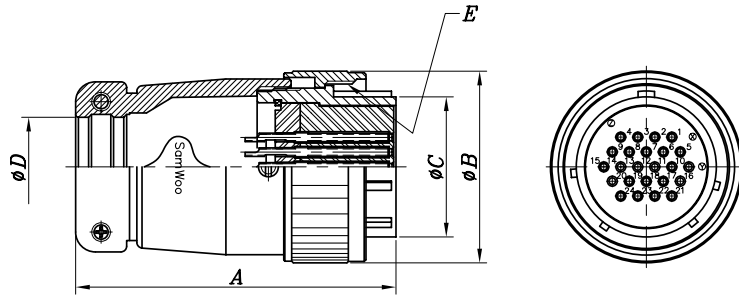

SCC6A-25-24S

Part Number	A	ØB	ØC	ØD	E
SCC6A-13-3S	45.7	21.5	12.7	8.0	M18×1.0P
SCC6A-13-5S					
SCC6A-16-7S	48.0	25.5	16.3	11.5	M22×1.0P
SCC6A-16-10S					

Part Number	A	ØB	ØC	ØD	E
SCC6A-21-10S	53.5	29.7	20.5	14.0	M26×1.0P
SCC6A-21-16S					
SCC6A-25-16S	56.5	33.8	24.7	17.5	M30×1.0P
SCC6A-25-24S					

SCC1A Adapter



SCC1A-25-24P

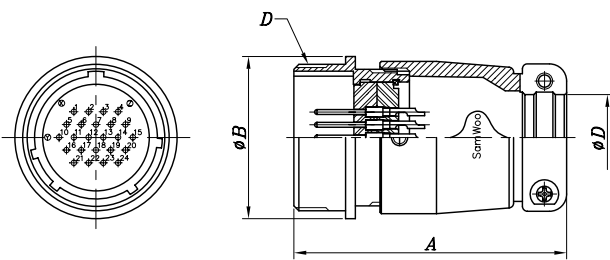

Part Number	A	ØB	ØC	ØD
SCC1A-13-3P	45.0	21.0	8.0	M18×1.0P
SCC1A-13-5P				
SCC1A-16-7P	47.8	25.0	11.5	M22×1.0P
SCC1A-16-10P				

Part Number	A	ØB	ØC	ØD
SCC1A-21-10P	51.5	29.0	14.0	M26×1.0P
SCC1A-21-16P				
SCC1A-25-16P	55.5	33.0	17.5	M30×1.0P
SCC1A-25-24P				

SCC2A Receptacle



SCC2A-25-24P

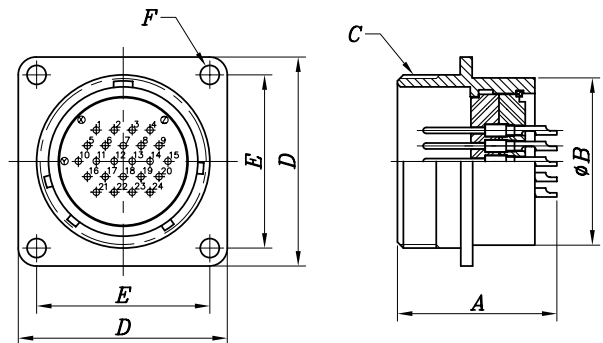

Part Number	A	ØB	C	D	E	F
SCC2A-13-3P	26.5	16.0	M18×1.0P	26.0	20.0	4-Ø3.3
SCC2A-13-5P						
SCC2A-16-7P	26.5	19.8	M22×1.0P	29.0	23.0	4-Ø3.3
SCC2A-16-10P						

Part Number	A	ØB	C	D	E	F
SCC2A-21-10P	25.5	24.0	M26×1.0P	32.0	26.0	4-Ø3.3
SCC2A-21-16P	26.3					
SCC2A-25-16P	26.2	27.9	M30×1.0P	35.0	29.5	4-Ø3.3
SCC2A-25-24P	26.5					

Specifications subject to change without notice. Consult Sam Woo Electronics for the latest specifications.